



Hold Down and Release System

The reliable device for satellite appendages

The ARA Mk3 Hold Down and Release System employs the principle of gradually reducing pretension in a stack by cutting an aramid holddown cable with a Thermal Knife.

This method yields a very low deployment shock when compared to a pyrotechnic device. Because the Thermal Knife system is insensitive to electro-magnetic disturbances, a spontaneous release is impossible. The Hold Down and Release System further comprises stackable cylindrical titanium CupCones, which are integrated in the elements to be restrained and deployed (e.g. in case of a solar array: the solar panels).

The stack is preloaded by a Kevlar restraint cable running from the top of the stack to the HDRS bracket at the bottom. The preloaded stack transfers loads from the restrained appendages via the CupCones into the interfacing foot bracket. Various adapter brackets can be provided to accommodate the HDRS on different interfaces.

The Thermal Knives can be used repetitively without refurbishment. Thus, all standard performance tests can be executed on the actual flight hardware at subsystem and system level. The only consumables in this process are the holddown cables.

Hold Down and Release System

The reliable device for satellite appendages

Strong heritage

To date, over 500 Hold Down and Release System units in combination with aramid cables have been successfully operated in orbit. This flight heritage is obtained not only on all our deployable Solar Arrays since 1996, but also on other subsystems such as:

- The SOHO Antenna Pointing Mechanism
- The Beppo-SAX concentrator shutter mechanism
- The ASAR Hold Down and Release Mechanism
- The Sciamachy Radiant Cooler Cover

Main characteristics

- TRL9: 100% success rate
- Modular lightweight holddown system
- Non-explosive actuation and release
- No outgassing or particle loss
- Easily resettable with new cables
- Restrains 1 to 6 stacked elements
- Standard variations available and customizable
- Pretension: 7000 N
- Besides standardized voltages, other operating voltages can be applied by using Pulse Width Modulation
- Full actuation redundancy
- No risk of spontaneous release
- In-situ testing of flight units possible

Reliable, low shock & customer resettable solution with 100% successful heritage

Cover photo: (credit NASA) One of our solar arrays on the commercial Cygnus ISS re-supply mission, equipped with four HDRS units per wing

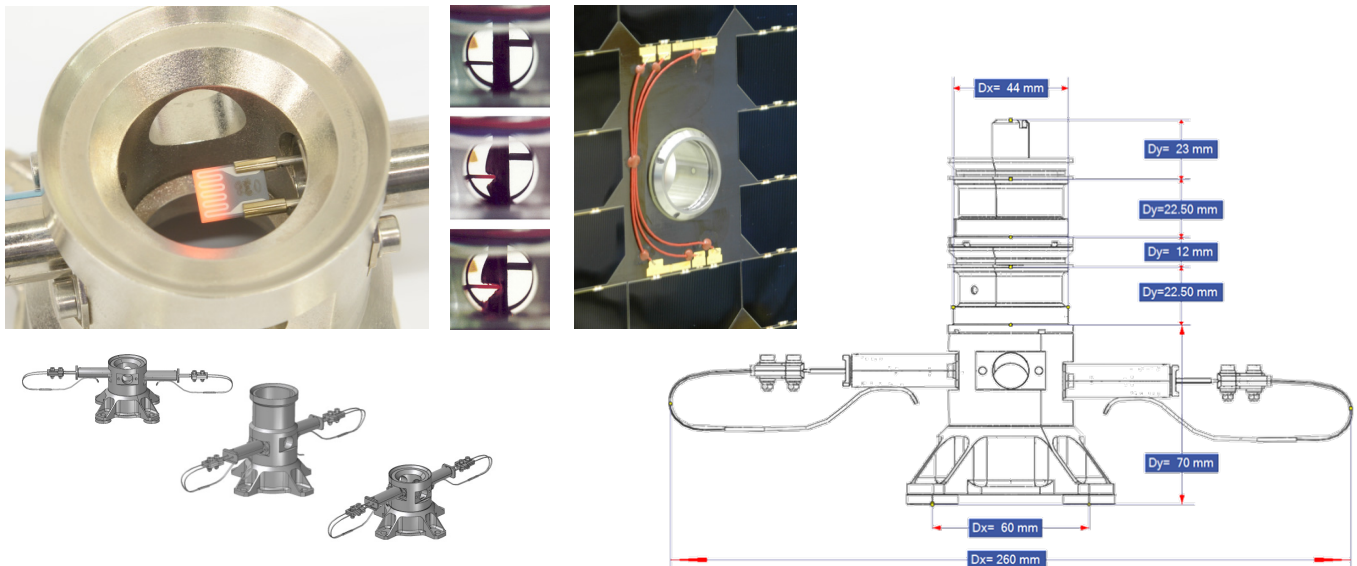

Performance Data	
Mass	500 – 750 gr. (1 – 6 Cup/Cones) per stack
Standard DC voltage	19.5 – 21.0 Volts
Current	inrush: 2.3 Amp nominal: 0.8 Amp
Release time	within 60 seconds
Allowable loads (launch configuration)	In-Plane shear (sliding) 7600 N Out-of-Plane on a bolt-flange 7400 N (equivalent to bending moment at I/F of 140 Nm)
Operational equipment temperature	from -60 to +85 °C
Interface to application	60 x 60 mm rectangular pitch (4 x M5 or M6)
HD bracket footprint	80 x 80 mm ²
Envelope including Thermal Knives and electrical wiring	l x w: ~260 x 80 mm ² h: 70 + n·22.5 + (n-1)·12 + ~23

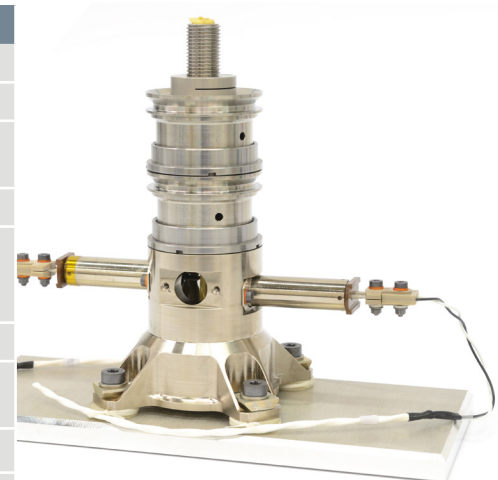

For further information please contact

Airbus Defence and Space Netherlands B.V. / Mr. Daniel Hendrix
T: +31 (0) 71 52 45 468 / E: mechanisms@airbusDS.nl